

UNICARRIERS[®]

□ FORKLIFT □



Electric Pneumatic Tire Lift Truck

80 Volt AC-Powered
9,000 - 12,000 lb. Capacity



MXL40 - MXL55 Series

MXL Series Applications

Experience levels of performance able to compete with IC engine lift trucks, while taking full advantage of the benefits electric forklifts bring to the table. The MXL series offers dependable performance, durability, and adaptability all while meeting a zero-emission footprint, and it's backed by an industry leading two-year warranty and excellent customer service. Featuring a sleek and compact design, incredible maneuverability, and intelligent control systems, the MXL series is ideal for the following industries:

- Wholesale trade (durable and non-durable goods)
- Trucking and Warehousing
- Food and Beverage
- Stone, Clay, and Glass
- Lumber
- Steel
- Chemicals, Textiles and Rubber
- Paper and Allied Products



The Total Electric Pneumatic Solution



NEVER QUIT.

It defines our lift trucks and the company that builds them.

Over the course of a century, the company known as UniCarriers Forklift took shape. As we grew and evolved into a US manufacturer with a global reach in nearly 100 countries worldwide, much has changed, but one thing hasn't: Our mission. UniCarriers Forklift is committed to providing you with the ultimate in reliability, performance, and value.

And that commitment can be seen in the MXL Series. The right choice when space is tight, their compact design, amazing maneuverability and intelligent control systems make them ideal for efficient handling in containers, trucks, drive-in racking and other cramped, fast-paced environments. They are also built to stand up to harsh, wet, dirty or dusty conditions. Add UniCarriers Forklift's legendary reliability, energy efficiency and durability — and you have the right lift truck to move your products, and your business, forward.



Up Your UpTime

Discover reliability features that cut downtime and keep your business up and running



Comfort Zone

Your drivers and your entire operation will benefit from our comfort & productivity features



Power & Performance

Reliable AC motors and controllers are only the beginning of our performance advantages



Play It Safe

Safety is everybody's business, and these models are all business when it comes to safety



Make It Yours

Already well appointed, the MXL series can be customized to meet your specific needs



To learn more, and find a dealer near you, visit LogisnextAmericas.com/UniCarriers



Up Your UpTime





Advanced Hydraulic Technologies

Optimizes mast and fork movements for smooth, fast, and safe material handling. Load sensing hydraulics adjust to load weight ensuring precise control of the mast and fork movements. In addition, Passive Sway Control Transfers some of the stresses and forces from the mast to the chassis of the truck allowing for confident control and durability in the mast when raising and lowering loads.



Reduce Downtime with Self-Diagnostics

To maximize uptime and maintain the performance levels of these durable lift trucks, we build easy servicing into their design. Integrated on-board diagnostics provide immediate lift truck status. It's intuitive dialogue display combined with accessible service history reduce troubleshooting time, so the unit is back in operation faster. **Everything is done** through a smart LCD panel. No handset device is needed.



The Brake You Need

Sealed wet disc brakes minimize brake wear and extend timing needed between brake service helping to reduce maintenance costs and total cost of ownership. The automatic parking brake activates without the need for traditional pedals, levers, or buttons.



Simplified Battery Maintenance & Replacement

Long-lasting battery enhances performance by minimizing the need for frequent charging or changes. Quick-connect access permits fast charging when necessary.



Comfort Zone



Built for maximum operator comfort, the ergonomically-designed MXL cabin features a quiet work environment. The electric platform limits noise, increases ease of drive and ultimately eliminates CO₂ emissions.



Improved Control and Productivity

Comfortable in all weather conditions with the optional temperature controlled cabin, which quickly heats up or cools down for optimal operator comfort. Sliding windows on each side of the lift truck help weatherproof the cabin and provide excellent visibility.



Ideal Operating Space

Large, ultra-comfortable operating space has been enhanced to meet the needs of drivers of different shapes and sizes for fatigue-free operation. The spacious footwell provides additional comfort to enjoy a natural, ergonomic, foot position. Quickly step and swing into and out of the spacious operator compartment. The full suspension vinyl seat with weight adjustment adds even more comfort.



Superior Visibility

Thanks to its optimized mast, steering wheel and dashboard, the MXL series maximizes visibility to load, forks, front and rear wheels for safe, confident operation in tight spaces. Clear informative full-color display is easy to read from any angle (even in direct sunlight). It's ideally positioned for operator reference and doesn't reduce the lift truck's all-round visibility. From there, the inclined and narrow dashboard design allows clear views from all directions.



Convenience at Your Fingertips

Fingertip control armrest is fully adjustable, ergonomically designed, and allows for comfortable hand-positioning, anatomical support during operation, and free movement.



Power & Performance



With the ability to handle heavier loads with less energy consumption, the MXL series answers the need for a high-performance solution capable of operating in applications where traditional IC lift trucks cannot, all while being more environmentally friendly and cost-effective.



Intuitive Drive System

The Intuitive Drive System smooths start and stop movements, increases agility, and adapts to the speed of the operators' foot movements.

It adapts performance rapidly in reaction to speed of pedal operation and helps ensure that travel movements, starts and stops are smooth. Intelligent curve control smoothly reduces lift truck speed when the lift truck senses that it is cornering. This lessens lateral forces on the operator, truck, and load.

High Efficiency Motors

Advanced technology such as acceleration boost provides additional power to the motor when the system senses speed reduction (e.g., ramps). High-efficiency electric motor delivers instant torque to help maintain productivity and lift truck speed, creating more torque at low speeds and reducing energy consumption.

Compensates for Load Weight

A load-sensing hydraulic system automatically adjusts for weight to maintain precise control of mast and fork movements. (In lift trucks without intelligent hydraulics, lifting and lowering feels very different when the weight of the load is varied.)

Smooth Steer Operations

MXL's all-wheel steering offers good grip, smooth turning, and extremely agile steering aided by the +100 degree rear steer axle that enables side turn without the need for rear movement.

Adjust for Your Needs

Standard pre-set ECO and PRO modes can be selected for the required application, but also the level necessitated by the experience of the operator.

Built to Last

As well as saving money daily with their low energy consumption, our lift trucks are able to help reduce the total cost of ownership through features such as:

- Sealing of components against water and other contaminants
- Use of highly durable materials and designs
- 1,000-hour PM intervals



Play It Safe



Work zone safety is a priority of the MXL series. With added features to protect and empower the operator, this electric lift truck offers exceptional visibility and safety.



Light Up Your Path.

Standard LED forward and reverse work lights increase awareness and visibility in low light conditions. Optional front and rear lights are available to further illuminate work zones and provide more warning in the lift truck's moving area.



Clearly Better

Excellent visibility thanks to the optimized mast. Combined with the inclined and narrow dashboard, steering wheel, and counterweight design, these features maximize visibility to load, forks, front and rear wheels for safe, confident operation in tight spaces.



Maximize Operator Safety

Electronic differential locks out front wheels to increase traction on slippery surfaces – this is activated automatically at small steering angles or manually via an optional front pedal.

In addition, ramp hold automatically activates the parking brake when on a ramp to hold position and prevents rollback when working on a grade and removing foot from accelerator pedal.



Make it Yours

Choose from a variety of options to customize your ride for your application and work environment. If you don't see what you need, contact your authorized UniCarriers Forklift dealer for help.



More Control Options

The optional dual joystick separates auxiliary operating functions and prevents accidental activation of hydraulic functions.

Smart and Durable

It's one of the most intelligent and durable lift trucks on the market today. Packed with features, it delivers the maneuverability, power and reliability you expect from UniCarriers Forklift. Modular design simplifies addition or replacement of parts, including overhead guard and cabin options.



Here to Serve You

To help you choose the right model and configuration, and maintain its productivity, we have a dedicated network of dealers. With their specialized knowledge, wide experience and excellent service they will support you in every way to help maximize your profits.

Features	Standard	Option
80V AC Drive System	•	
Preset ECO and PRO performance modes	•	
Side battery extraction	•	
Multifunction interactive full color display	•	
Cornering Speed Control	•	
Standard wet disc brakes	•	
TruckTool diagnostics	•	
Operator Presence System (OPS)	•	
Full-suspension vinyl Grammar MSG65 Seat	•	
Integrated LED worklights	•	
Fingertip Control armrest		•
Battery extraction options		•
Additional lights and awareness options		•
Temperature controlled cabin (A/C)		•
PIN code access		•
Automatic tilt centering		•
Panel cabins		•
Side shifters		•
Fork positioner		•
Multiple tire options		•



DIMENSIONS

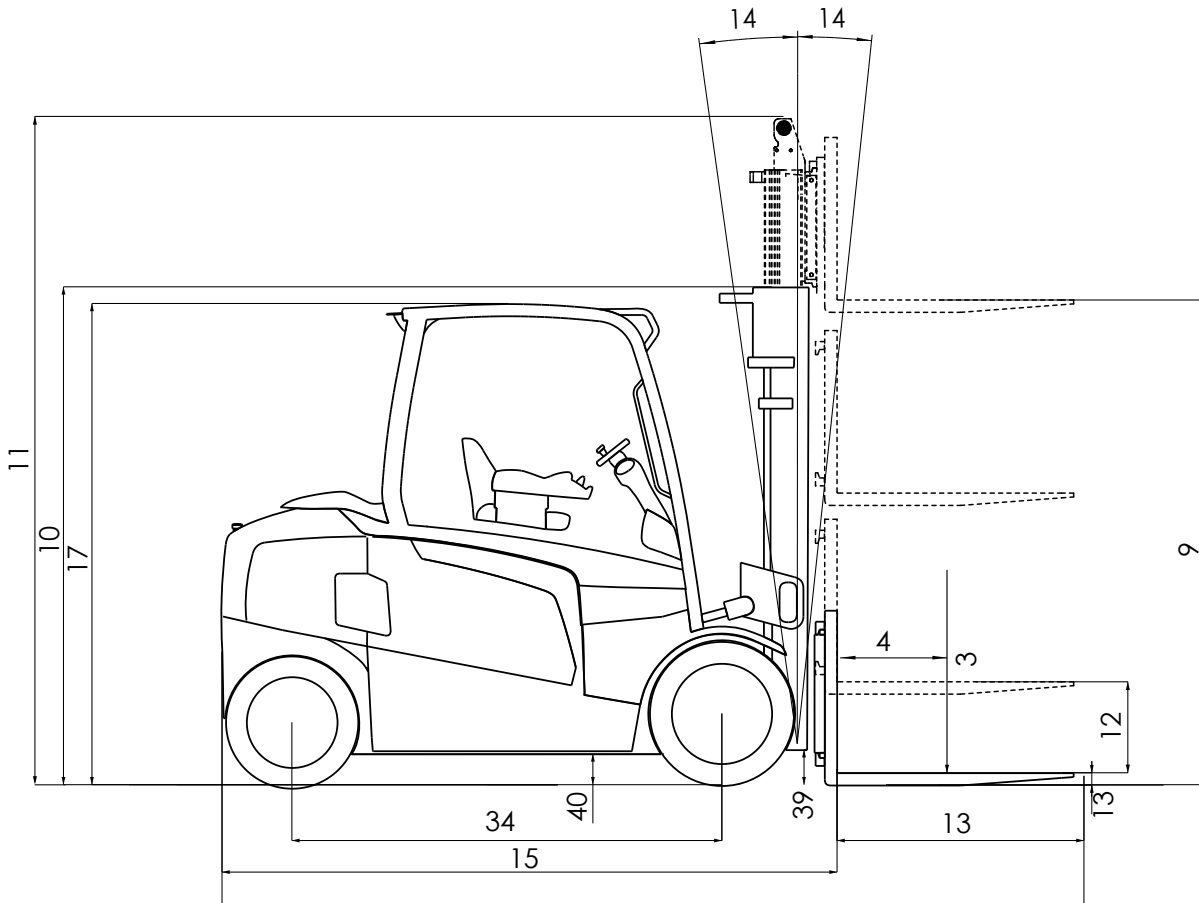
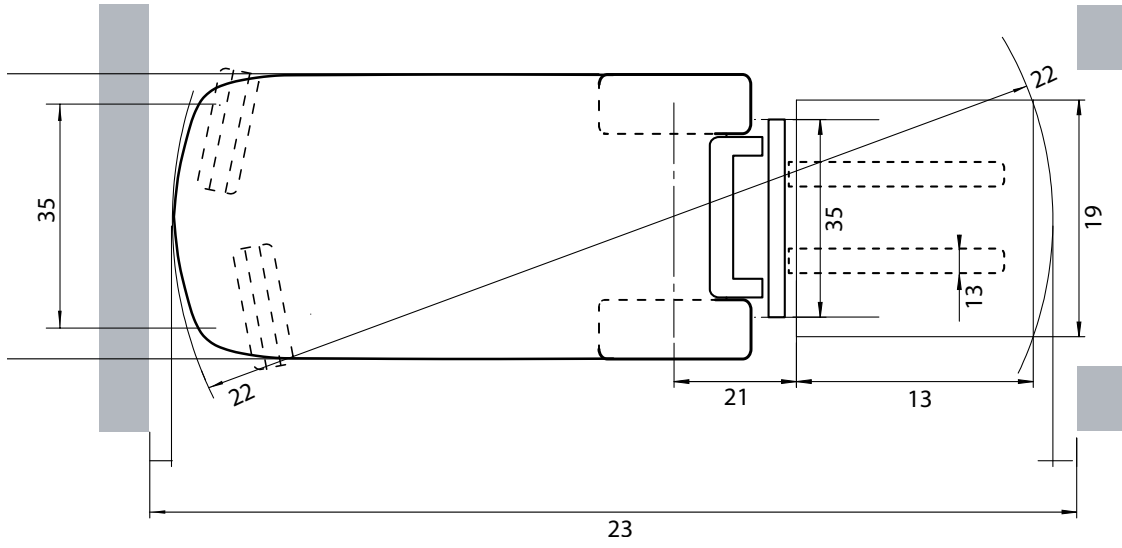

MAIN TRUCK SPECIFICATIONS

MAIN TRUCK SPECIFICATIONS											
CHARACTERISTICS	1	Manufacturer's Name			UniCarriers	UniCarriers	UniCarriers	UniCarriers	UniCarriers	UniCarriers	
	2	Model	Model designation		MXL40	MXL45	MXL50C	MXL50	MXL50H	MXL55H	
	3	Rated Load Capacity		lb (kg)	9000 (4000)	10000 (4500)	11000 (4990)	11,000 (4990)	11000 (5000)	12000 (5500)	
	4	Load Center	Distance	in (mm)	24 (600)	24 (600)	24 (600)	24 (600)	24 (600)	24 (600)	
	5	Power Type	Electric	V	Electric/80v	Electric/80v	Electric/80v	Electric/80v	Electric/80v	Electric/80v	
	6	Operator Orientation			Seated	Seated	Seated	Seated	Seated	Seated	
DIMENSIONS	7	Tire Type	Front & rear		Solid Pneu. SE	Solid Pneu. SE	Solid Pneu. SE	Solid Pneu. SE	Solid Pneu. SE	Solid Pneu. SE	
	8	Wheels	Number - front/rear (x=driven)		2x/2	2x/2	2x/2	2x/2	2x/2	2x/2	
	9	Mast	Maximum fork height	in (mm)	130.0 (3300)	130.0 (3300)	130.0 (3300)	130.0 (3300)	130.0 (3300)	130.0 (3300)	
	10		Mast lowered (OHL)	in (mm)	95.3 (2420)	95.3 (2420)	95.3 (2420)	95.3 (2420)	95.3 (2420)	95.3 (2420)	
	11		Mast extended with LBR	in (mm)	165.5 (4205)	165.5 (4205)	165.5 (4205)	165.5 (4205)	171.0 (4345)	171.0 (4345)	
	12		Standard freelif	in (mm)	5.9 (150)	5.9 (150)	5.9 (150)	5.9 (150)	6.3 (160)	6.3 (160)	
	13	Forks	Thickness & width & Length	in (mm)	1.9 x 5.9 x 47.2 (50 x 150 x 1200)	1.9 x 5.9 x 47.2 (50 x 150 x 1200)	1.9 x 5.9 x 47.2 (50 x 150 x 1200)	1.9 x 5.9 x 47.2 (50 x 150 x 1200)	2.3 x 5.9 x 47.2 (60 x 150 x 1200)	2.3 x 5.9 x 47.2 (60 x 150 x 1200)	
	14	Tilt Angle	Standard mast - fwd/back	degree	6/8	6/8	6/8	6/8	6/8	6/8	
	15	Overall Dimensions	Length (to face of forks)	in (mm)	111.2 (2825)	111.2 (2825)	111.2 (2825)	116.9 (2970)	117.7 (2990)	117.7 (2990)	
	16		Width (standard tires)	in (mm)	53.9 (1370)	53.9 (1370)	57.0 (1450)	57.0 (1450)	57.0 (1450)	57.0 (1450)	
	17		Height - top of OHG	in (mm)	92.1 (2340)	92.1 (2340)	92.1 (2340)	92.1 (2340)	92.1 (2340)	92.1 (2340)	
	18		Height - top of standard LBR	in (mm)	5.5 (140)	5.5 (140)	5.5 (140)	5.5 (140)	5.5 (140)	5.5 (140)	
	19		Width - standard carriage	in (mm)	46.85 (1190)	46.85 (1190)	46.85 (1190)	46.85 (1190)	46.85 (1190)	46.85 (1190)	
	20	Grade Clearance	Ramp breakover angle (with/without load)	%	15	15	14	14	13.5	13	
	21	Overhang	Front	in (mm)	21.3 (540)	21.3 (540)	21.3 (540)	21.3 (540)	22.0 (560)	22.0 (560)	
	22	Turning Radius	Minimum outside	in (mm)	90.1 (2289)	90.1 (2289)	90.1 (2289)	95.8 (2434)	95.8 (2434)	95.8 (2434)	
	23	Min Right Angle Stack	1000 x 1200 mm pallets, crosswise / 800 x 1200 mm pallets, lengthwise	in (mm)	111.2 (2825)	111.2 (2825)	111.2 (2825)	116.9 (2970)	117.7 (2990)	117.7 (2990)	
	PERFORMANCE	24	Speed Maximum	Travel - loaded / unloaded	mph (km/h)	11 / 12 (18 / 20)	11 / 12 (18 / 20)	11 / 12 (18 / 20)	11 / 12 (18 / 20)	11 / 12 (18 / 20)	11 / 12 (18 / 20)
		25		Lift - loaded / unloaded	fpm (mm/sec)	80.7 / 104.3 (.41 / .53)	74.8 / 104.3 (.38 / .53)	68.8 / 104.3 (.35 / .53)	68.8 / 104.3 (.35 / .53)	68.8 / 104.3 (.35 / .53)	62.9 / 104.3 (.32 / .53)
26		Lowering - loaded / unloaded		fpm (mm/sec)	104.3 / 100.3 (.53 / .51)	102.3 / 100.3 (.52 / .51)	102.3 / 100.3 (.52 / .51)	102.3 / 100.3 (.52 / .51)	102.3 / 100.3 (.52 / .51)	100.3 / 100.3 (.51 / .51)	
27		Drawbar Pull Maximum	Full load	lb (N)	17300 / 18400	17300 / 18400	17300 / 18400	21500 / 22600	21500 / 22600	21500 / 22600	
28	Gradeability Maximum	Full load (with/without load)	%	15.8 / 26.6	15.6 / 23.7	14.6 / 22.6	16.6 / 28.7	16.5 / 28.2	16.4 / 27.3		
WEIGHT	29	Truck Weight	Empty, min. battery	lb (kg)	16071 (7290)	16860 (7648)	17617 (7991)	18401 (8347)	18677 (8472)	19204 (8711)	
	30	Weight Distribution	Full load front/rear - min. battery	lb (kg)	22134 / 2755 (10040 / 1250)	23798 / 2982 (10795 / 1353)	25516 / 3123 (11574 / 1417)	25492 / 3933 (11563 / 1784)	26475 / 3225 (12009 / 1463)	28326 / 3112 (12799 / 1412)	
	31		No load front/rear - min. battery	lb (kg)	8602 / 7469 (3902 / 3388)	8575 / 8284 (3890 / 3758)	8602 / 9014 (3902 / 4089)	8983 / 9418 (4075 / 4272)	9334 / 9343 (4234 / 4238)	9360 / 9843 (4246 / 4465)	
CHASSIS & WHEELS	32	Tire Size	Front	in	250x15/7.00 (711x225)	250x15/7.00 (711x225)	355/50x15/9.75 (710x284)	355/50x15/9.75 (710x284)	355/50x15/9.75 (710x284)	355/50x15/9.75 (710x284)	
	33		Rear	in	7.00x12/5.00 (650x172)	7.00x12/5.00 (650x172)	7.00x12/5.00 (650x172)	7.00x12/5.00 (650x172)	7.00x12/5.00 (650x172)	7.00x12/5.00 (650x172)	
	34	Wheelbase		in (mm)	76.6 (1946)	76.6 (1946)	76.6 (1946)	82.3 (2090)	82.3 (2090)	82.3 (2090)	
	35	Tread - Center of Tire	Front / rear (standard tires)	in (mm)	45.0/46.0 (1143 / 1169)	45.0/46.0 (1143 / 1169)	45.4 / 46.0 (1154 / 1169)	45.4 / 46.0 (1154 / 1169)	45.4 / 46.0 (1154 / 1169)	45.4 / 46.0 (1154 / 1169)	
	36	Headroom	SIP to bottom pf OHG	in (mm)	46.85 (1190)	46.85 (1190)	46.85 (1190)	46.85 (1190)	46.85 (1190)	46.85 (1190)	
	37	Counterweight Height		in (mm)	59.0 (1500)	59.0 (1500)	59.0 (1500)	59.0 (1500)	59.0 (1500)	59.0 (1500)	
	38	Step Height		in (mm)	19.0 (480)	19.0 (480)	19.0 (480)	19.0 (480)	19.0 (480)	19.0 (480)	
	39	Ground Clearance	Under mast	in (mm)	5.9 (150)	5.9 (150)	5.9 (150)	5.9 (150)	5.9 (150)	5.9 (150)	
	40		Under frame, center of wheelbase	in (mm)	5.9 (150)	5.9 (150)	5.9 (150)	5.9 (150)	5.9 (150)	5.9 (150)	
	41	Service Brake	Type		Hydraulic	Hydraulic	Hydraulic	Hydraulic	Hydraulic	Hydraulic	
42	Parking Brake	Type		Hydraulic	Hydraulic	Hydraulic	Hydraulic	Hydraulic	Hydraulic		
43	Steering	On-demand		AC electronic	AC electronic	AC electronic	AC electronic	AC electronic	AC electronic		
DIN 320A 48V LINE	44	Traction Motor	Type / Rating (1-hour)	kW	AC / 2 x 16 kW	AC / 2 x 16 kW	AC / 2 x 16 kW	AC / 2 x 16 kW	AC / 2 x 16 kW	AC / 2 x 16 kW	
	45		Control type		AC	AC	AC	AC	AC	AC	
	46	Pump Motor	Type / Rating (5-minute)	kW	AC / 80/775 kW	AC / 80/775 kW	AC / 80/775 kW	AC / 80/775 kW	AC / 80/775 kW	AC / 80/775 kW	
BATTERY	47	Battery Compartment Size	W x H - Maximum	in (mm)	40.5 x 30.9 (1028 x 785)	40.5 x 30.9 (1028 x 785)	40.5 x 30.9 (1028 x 785)	40.5 x 30.9 (1028 x 785)	40.5 x 30.9 (1028 x 785)	40.5 x 30.9 (1028 x 785)	
	48		L - Maximum	in (mm)	33.7 (855)	33.7 (855)	33.7 (855)	39.3 (999)	39.3 (999)	39.3 (999)	
	51	Battery	Type		Lead acid	Lead acid	Lead acid	Lead acid	Lead acid	Lead acid	
	52	Capacity	Maximum	AH/5h	775	775	775	930	930	930	
	53	Weight	Minimum / Maximum	lb (kg)	3,885 / 4,410 (1,760 / 2,000)	3,885 / 4,410 (1,760 / 2,000)	3,885 / 4,410 (1,760 / 2,000)	4,435 / 5,180 (2,010 / 2,350)	4,435 / 5,180 (2,010 / 2,350)	4,435 / 5,180 (2,010 / 2,350)	
	54	Lead Length	Position B	in (mm)	19.7 (500)	19.7 (500)	19.7 (500)	19.7 (500)	19.7 (500)	19.7 (500)	

Reliability.

It's the defining trait of our company and our forklifts.



UniCarriers Forklift's roots extend back over 100 years, and over that time, strong, reliable performance has always been the hallmark of our organization, our people and our equipment.

Today, our unrivaled reliability continues to provide UniCarriers Forklift's customers with a competitive edge. And together, we move the merchandise that moves world commerce with greater efficiency, economy and reliability.

When it comes to providing forklifts that make a difference for our customers and theirs...

We Never Quit.

UNICARRIERS[®]
[**FORKLIFT**]

LogisnextAmericas.com/UniCarriers

SB-MXL40-55 06-2022 Printed in U.S.A.

© 2022 Mitsubishi Logisnext Americas Inc. UniCarriers[®] is a registered trademark of Mitsubishi Logisnext Co., Ltd. Mitsubishi Logisnext Americas, Inc. reserves the right to make product changes relating to colors, equipment, specifications or available options without notice. For more information, contact your UniCarriers Forklift representative.





FORKLIFT SYSTEMS

ABOUT US

Forklift Systems is a 40+ year old, privately held, family owned full service material handling company. Founded in 1978 and headquartered in Nashville, Tennessee, we have multiple locations serving thousands of customers in Alabama, Kentucky, Indiana, and Tennessee.

Our focus is in helping our customers achieve the absolute lowest lifetime cost when purchasing and maintaining powered industrial equipment. By providing outstanding equipment, and partnering with our customers, we provide ownership and maintenance programs that cut the time and cost associated with owning material handling and forklift fleets.

Our award winning service company is a one stop source for all your material handling needs including forklifts, aerial lifts, rack systems, industrial vehicles, floor sweepers and scrubbers, and much more.

We offer many top brands like JLG, Genie, Advance, UniCarriers, and Doosan. Services include forklift operator training and safety courses, parts programs, and fleet maintenance programs. We can help design your warehouse and provide engineered rack system layouts for your facility.

Give us an opportunity and discover the Forklift Systems difference.



PROUDLY IN SERVICE

40+ YEARS



3

Locations



COMPANIES THAT TRUST US



WHAT OUR CUSTOMERS ARE SAYING

“You guys give us great response time on service and go the extra mile to be sure our equipment is being productive.” – Steve White

“I’m always very pleased with the techs and the service department! Everyone they have sent out has been great!” – Mike Stuart

“Your technician was awesome and very knowledgeable and was able to explain everything that was going on. I appreciate the timeliness of the service.” – Steve White

BRANDS WE REPRESENT



Contact Us

800 - 752 - 1882

TENNESSEE HEADQUARTERS

884 Elm Hill Pike
Nashville, TN, 37210
615-255-6321
contact@forkliftsystems.com

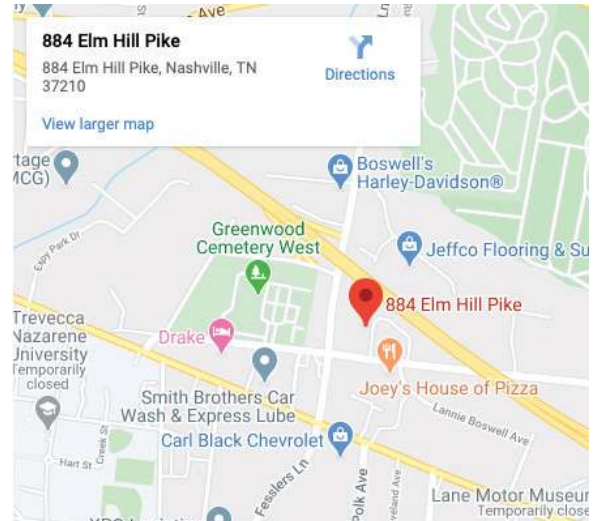

ALABAMA HEADQUARTERS

132 West Park Drive
Birmingham, AL, 35211
205-945-1112
contact@forkliftsystems.com

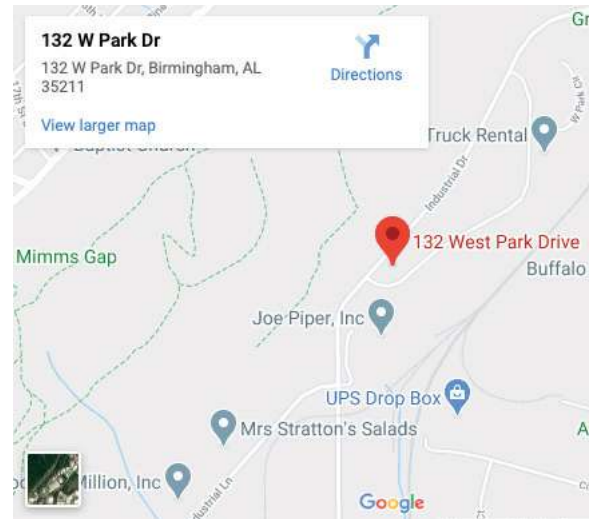

KENTUCKY HEADQUARTERS

4300 Chef's Way #2
Louisville, KY 40218
502-654-8999
contact@forkliftsystems.com

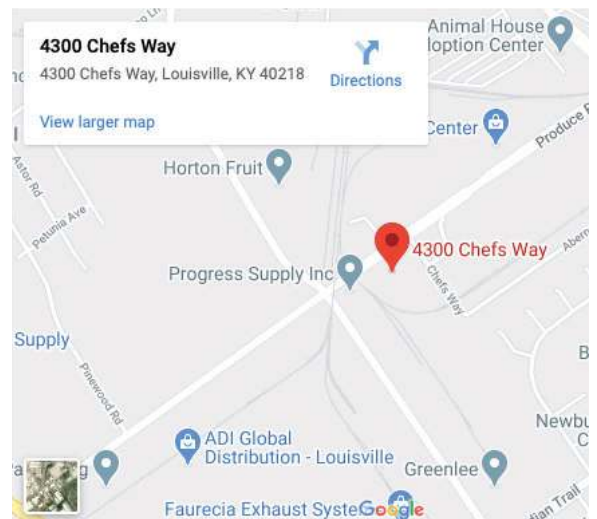

PRODUCTS NEW & USED AVAILABLE



Lithium Forklifts



Electric Pallet Trucks



Electric Sit Down Forklifts



Reach Truck



Electric Stacker



Order Picker



Very Narrow Aisle



Cushion Forklifts



Pneumatic Forklifts



Large Capacity Cushion



Large Capacity Pneumatics



Truck Mounted Forklifts

PRODUCTS NEW & USED AVAILABLE



Diesel Forklifts



Scissor Lifts & Boom Lifts



Four Direction Lifts



Straddle Carriers



Poultry Lift



Rider Sweeper & Scrubber



Walkie Sweeper & Scrubber



Personnel Shuttles



Industrial Utility Vehicles



Rack & Storage Systems



In-Plant Office - Building



800 - 752 - 1882
www.forkliftsystems.com